

# A robust fetal ECG detection method for abdominal recordings

Suzanna M M Martens<sup>1</sup>, Chiara Rabotti<sup>1</sup>, Massimo Mischi<sup>1</sup> and Rob J Sluijter<sup>2</sup>

<sup>1</sup> Department of Electrical Engineering, University of Technology Eindhoven, Eindhoven, The Netherlands

<sup>2</sup> Philips Research Laboratories, Eindhoven, The Netherlands

E-mail: [smm.martens@gmail.com](mailto:smm.martens@gmail.com)

Received 29 November 2006, accepted for publication 8 February 2007

Published 7 March 2007

Online at [stacks.iop.org/PM/28/373](http://stacks.iop.org/PM/28/373)

## Abstract

In this paper, we propose a new method for FECG detection in abdominal recordings. The method consists of a sequential analysis approach, in which the *a priori* information about the interference signals is used for the detection of the FECG. Our method is evaluated on a set of 20 abdominal recordings from pregnant women with different gestational ages. Its performance in terms of fetal heart rate (FHR) detection success is compared with that of independent component analysis (ICA). The results show that our sequential estimation method outperforms ICA with a FHR detection rate of 85% versus 60% of ICA. The superior performance of our method is especially evident in recordings with a low signal-to-noise ratio (SNR). This indicates that our method is more robust than ICA for FECG detection.

Keywords: fetal electrocardiography, signal processing, electrophysiological measurements

## 1. Introduction

Monitoring the fetal cardiac activity can provide important information to obstetricians for the assessment of the fetal well-being (van Geijn and Copray 1994). Doppler ultrasound is now routinely used for the measurement of the fetal heart rate (FHR) during pregnancy and delivery (Lewis 2003). The FHR variability is related to the autonomic nervous system and it is an important parameter to assess fetal distress.

However, the FHR is the only parameter obtained by Doppler ultrasound, while research has shown that a global assessment of morphological and temporal parameters of the

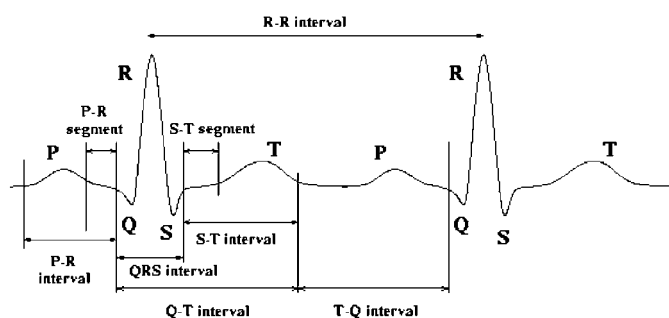


Figure 1. Nomenclature of the electrocardiogram (ECG).

electrocardiogram (ECG) of the foetus during gestation can provide additional information about the fetal well-being. In fact, changes in parameters such as the PR- and PQ-interval, the width of the QRS complex, and changes in the P wave, the T wave and the ST segment (figure 1) have been associated with the level of fetal oxygenation (Symonds *et al* 2001). The fetal ECG (FECG) can be obtained by applying an electrode on the fetal scalp or by means of ordinary electrodes placed on the mother's abdomen (Crowe *et al* 1996). The use of a scalp electrode is highly invasive and it is only possible during labour, after the breaking of the water. In contrast, abdominal FECG recordings provide a non-invasive diagnostic tool to assess fetal well-being during both pregnancy and delivery. Furthermore, the abdominal FECG offers the possibility of long-term at-home monitoring of high-risk pregnancies. This is a further advantage of the FECG with respect to Doppler ultrasound, which is unsuitable for long-term ambulant monitoring due to its high sensitivity to movements and the need for frequent repositioning the ultrasound probe (Crowe *et al* 1995). Nevertheless, the detection of the FECG from the mother's abdomen involves the detection of a small amplitude fetal signal overwhelmed by a large number of interference signals and noise. Baseline drift, ECG amplitude modulation due to respiration, power-line interference, electromyogram (EMG) and motion artefacts are among the most significant interference signals that may corrupt ECG recordings (Friesen *et al* 1990). In abdominal FECG recordings, the mother ECG (MECG) represents an additional and predominant source of interference.

Numerous attempts have been made to detect the FECG in abdominal recordings. To this end, the authors have mainly focused on the removal of the MECG using classical filtering techniques (Bemmel and van der Weide 1966) or estimation techniques, such as adaptive filtering (Widrow *et al* 1975), subtraction (Meijer 1981) and averaging (Abboud and Sadeh 1989, Cerutti *et al* 1986). However, none of these proposed methods has been validated on a large database of real abdominal ECG measurements. This limited reproducibility of the measurements may suggest a scarce performance due to the inaccurate removal of the MECG and to the presence of other significant interference signals.

Recently, a completely different approach for FECG detection has been considered. Some authors formulated the FECG detection as a blind source separation (BSS) problem (Callaerts *et al* 1986, Zarzoso *et al* 1997, Lathauwer *et al* 2000). BSS methods, e.g., principal component analysis (PCA) and independent component analysis (ICA), are algebraic methods for the estimation of unobserved components from multidimensional data. The performance of ICA for FECG detection has been recently shown to achieve accurate results for FECG detection on a large database of records (Taylor *et al* 2003, 2005). Furthermore, some authors suggested that this technique performs better than the existing non-blind methods (Zarzoso and Nandi 2001,

Comani *et al* 2004). Nevertheless, the applicability of BSS methods for FECG detection in abdominal recordings is controversial (Ifeachor *et al* 2004, Sabry-Rizk *et al* 2001). The ‘blind’ approach does not take into account the *a priori* information about the signal of interest, nor about the interference signals to be separated, implying an unpredictable and uncontrollable behaviour. Furthermore, the relationship between the physiological sources of the cardiac activity and the statistically independent sources estimated by ICA is not clear (Zarzoso and Nandi 2001).

In this paper, we propose a new non-blind method for FECG detection in abdominal recordings during pregnancy and labour. The method consists of a sequential analysis approach, in which the *a priori* information about the interference signals is used for the detection of the FECG. Our method is evaluated on a set of 20 abdominal recordings from pregnant women with different gestational ages. Its performance in terms of FHR detection is compared with that of ICA. The results show that our sequential estimation method performs better than ICA, especially in recordings characterized by a low signal-to-noise ratio (SNR). This indicates that our method is more robust than ICA for FECG detection.

## 2. Methodology

### 2.1. Independent component analysis

ICA is a mathematical technique for recovering unobserved source signals (components) from observed signal mixtures. The observed signals  $x_1(k), \dots, x_q(k)$  are assumed to be linear and instantaneous mixtures of the source signals  $s_1(k), \dots, s_m(k)$  and may contain additive Gaussian noise  $n_1(k), \dots, n_m(k)$ . This can be compactly represented in a conventional vector–matrix notation as

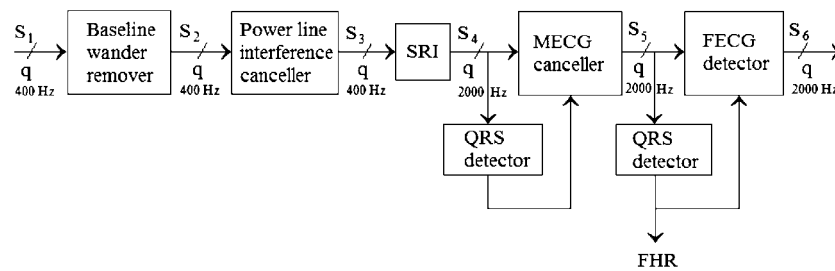
$$\underline{x}(k) = A\underline{s}(k) + \underline{n}(k), \quad (1)$$

where  $\underline{x}(k)$ ,  $\underline{s}(k)$  and  $\underline{n}(k)$  are vectors containing the observed mixtures, the source signals and the noise contribution, respectively.  $A$  is referred to as the mixing matrix and contains the mixture coefficients. Each source is assumed to be a random variable with non-Gaussian distribution. Furthermore, the sources are assumed to be statistically independent (Hyvarinen *et al* 2001).

The goal of ICA consists of the estimation of the matrix  $A$ , and eventually of the source vector  $\underline{s}(k)$ , given only the realizations of the observed mixture vector  $\underline{x}(k)$ . For this purpose, a number of criteria can be considered on the basis of maximization of non-gaussianity (Hyvarinen 1999), maximum likelihood, minimization of mutual information (Comon 1994), tensorial methods (Cardoso 1989) and nonlinear decorrelation (Jutten and Taleb 2000).

In the case of a noise-free model, i.e.,  $\underline{n}(k) = \underline{0}$  in (1), the identification of the mixing matrix  $A$  and the sources  $\underline{s}(k)$  is guaranteed as long as the sources are independent and non-Gaussian, and the number of sensors is equal or larger to the number of independent sources to be estimated. If  $\underline{n} \neq \underline{0}$  only the identification of the mixing matrix  $A$  is guaranteed (Hyvarinen *et al* 2001) and  $\underline{s}(k) = (\underline{x}(k) - \underline{n}(k))A^{-1}$ . As a result, we obtain a noisy estimates of the sources. Therefore, a reduction of the noise before applying ICA, e.g., by filtering, may significantly improve the performance of the BSS.

When ICA is applied to abdominal FECG detection, the observed signal mixtures  $\underline{x}(k)$  are the signals measured with the electrodes placed on the mother abdomen. The unobserved source signals  $\underline{s}(k)$  are the FECG, which is the signal of interest, and a number of interferences, such as the baseline wander, the power-line interference, the MECG and the uterine EMG. The



**Figure 2.** General block scheme of the proposed sequential analysis for FECG detection. The input  $S_1$  contains the abdominal FECG recordings ( $q$  channels). The outputs are the FHR and the average FECG complex per channel  $S_6$ . The scheme contains a number of blocks including a complete algorithm for the removal of the baseline wander, the power-line interference and the MECG. The SRI represents a sampling-rate inserter.

measurement noise is considered additive Gaussian noise. The MECG is usually estimated by ICA as three independent MECG source signals in accordance with the lead vector concept introduced by Burger and Van Milaan (Plonsey and Fleming 1969). This theory states that at a certain distance from the heart, its bioelectrical activity can, as a first-order approximation, be represented by a three-dimensional current dipole, which is fixed in position but variable in magnitude and orientation. As a result, the MECG measured on the mother's body is the superimposition of three orthogonal and independent components. The number of independent source signals for the FECG is not necessarily equal to three, since is subject to changes during pregnancy (Oostendorp 1989).

Due to the mentioned publications in which ICA has been successfully and extensively employed on real measurements, in this paper we will compare our sequential analysis method with ICA. For the implementation we will employ the joint approximate diagonalization of eigenmatrices (JADE) algorithm (Cardoso 1989), a non-gaussianity based ICA algorithm appropriate for FECG detection (Harmeling *et al* 2004).

## 2.2. Sequential analysis

The proposed sequential analysis method detects the FECG by estimating and removing the interference signals step-by-step, using *a priori* information about the interference signals and the signal of interest. Figure 2 shows the block scheme of the sequential analysis method for the detection of the FECG. The scheme is implemented in Matlab<sup>®</sup> (The MathWorks).

The input  $S_1$  contains the multi-channel abdominal FECG data.  $S_1$  passes through the baseline wander remover, which attenuates the low-frequency components. The output data  $S_2$  are processed by the power-line interference canceller, which removes the power-line interference including its harmonics in each channel. The sampling rate of the data in  $S_3$  is increased from 400 Hz to 2000 Hz in  $S_4$ . The positions of the mother QRS complexes in  $S_4$  are determined by the QRS detector. With this information the MECG canceller removes the MECG from each channel leading to  $S_5$ . Next, the positions of the fetal QRS complexes in  $S_5$  are determined by the QRS detector. This information is used by the FECG detector, whose output  $S_6$  contains an average FECG complex for each channel over 150 FECG complexes.

In the following subsections, the baseline wander remover, the power-line interference canceller, the MECG canceller and the FECG detector will be discussed as well as the QRS detector.

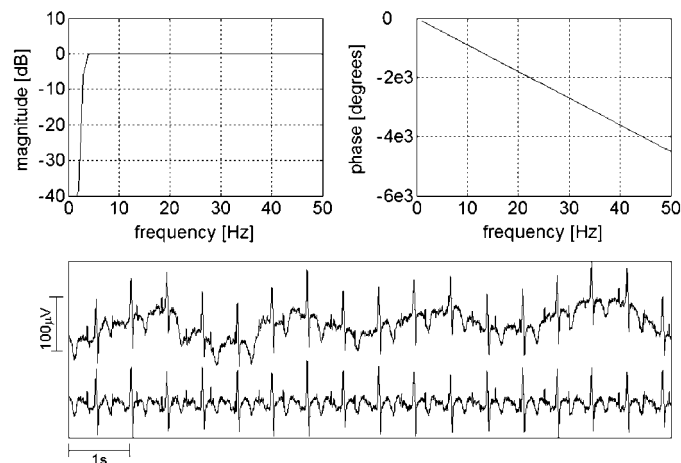
*2.2.1. Baseline wander remover.* Baseline wander is a common phenomenon in biomedical electric recordings. It is caused by the patient's breathing or movements (Onaral *et al* 1984). The frequency range of the baseline wander due to breathing usually has an upper limit smaller than 1 Hz. However, when the patient is performing exercise, the upper limit may be larger (van Alste *et al* 1986, Laguna *et al* 1992). Patient movements are reflected in transient baseline changes resembling one cycle of a sine wave with a duration of 100 to 500 ms (Friesen *et al* 1990), which is equivalent to a frequency range from 2 to 10 Hz. The FHR normally lies between 120 and 160 beats  $\text{min}^{-1}$  (bpm) (Abboud and Sadeh 1990) corresponding to a fundamental FECG frequency between 2 and 2.7 Hz. In pathological cases, the FHR may be outside this range, resulting in a fundamental FECG frequency around 1.3 Hz (fetal bradycardia) or 3.3 Hz (fetal tachycardia).

The standard technique for removing the baseline wander in ECG recordings consists of high-pass filtering the data. The adopted filter is usually a linear-phase FIR filter in order to prevent signal distortion. In abdominal FECG recordings, however, the application of a high-pass filter involves a trade-off between the complete removal of the baseline wander and the preservation of the FECG waveform due to their spectral overlap.

Other baseline wander removal methods reported in the literature involve the application of a high-pass filter with time-varying cut-off frequency depending on the instantaneous heart rate (Sornmo 1993) or the subtraction of an estimate of the baseline wander using polynomials or cubic splines (Meyer and Keiser 1977, Gradwohl *et al* 1988, McManus *et al* 1985). However, the first approach requires the detection of the heart rate, which in our case is complicated by the extremely small SNR of the FECG, while the second approach may produce large errors in the baseline wander estimation in the presence of fast changing components and noise (Raifel and Ron 1997). Therefore, we have resorted to the application of a classical linear-phase high-pass FIR filter (1000 taps) with a fixed cut-off frequency  $f_c$  of 3 Hz at a sampling frequency of 400 Hz. This filter works on all the channels in  $S_1$  separately. We found that the selected value for  $f_c$  adequately attenuates the large amount of baseline wander though it may cause a slight FECG distortion. The filter's delay of 1.25 s is negligible in the context of fetal monitoring. Figure 3 shows the filter characteristics and an example of an abdominal channel before and after the removal of the baseline wander.

*2.2.2. Power-line interference canceller.* Power-line interference may significantly corrupt electro-physiologic recordings. The interference consists of a sine wave with a centre frequency around 50 Hz and harmonics at multiples of this frequency. For the elimination of this interference in  $S_2$  we have implemented an adaptive noise cancelling technique which iteratively estimates amplitude, frequency and phase of the power-line interference in each channel, and it is specifically tailored for its use in ECG signals (Martens *et al* 2006). This technique has been shown to effectively eliminate the power-line interference in ECG recordings resulting in signal-to-interference ratios larger than 30 dB independently of the power-line interference amplitude in the original signals.

*2.2.3. QRS detector.* In our sequential analysis method, the QRS detector appears twice. It acts on  $S_4$  and  $S_5$  for the detection of the MECG and FECG periodicity, respectively (see figure 2). The locations of the mother QRS complexes are needed in the MECG canceller. The locations of the fetal QRS complexes provide the FHR and are employed in the FECG



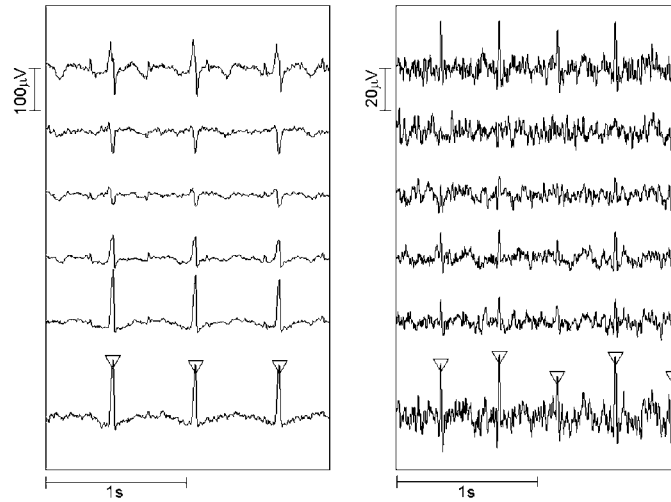
**Figure 3.** Baseline wander removal. The upper plot shows the amplitude (left) and phase (right) of the high-pass filter transfer function. The lower plot shows one abdominal FECG channel (upper signal) and the same channel after baseline wander removal with the filter (lower signal).

detector. According to our simulations, if the maternal QRS detection and MECG cancellation is performed at a sampling frequency of 400 Hz, the remaining maternal QRS amplitude after MECG cancellation may be of the same order of magnitude as the FECG amplitude, hampering a successful FECG detection. A matching between MECG complex template and actual MECG complexes that leads to an efficient MECG cancellation requires a sampling frequency of at least 2000 Hz. Therefore, the data are upsampled before maternal QRS detection and MECG cancelling.

Our QRS detector consists of a multi-channel QRS enhancement method and the QRS detection itself. The multi-channel QRS enhancement method generates one signal from all the channels by exploiting the large inter-channel correlation of the ECG components and the small inter-channel correlation of the noise. The optimal combination of the channels is derived by performing a principal component analysis (PCA) on the data set after normalizing the channel variance as described in detail in (Martens *et al* 2005). The first principal component is the combination of the channels that yields maximum variance. Under the assumption that the channels only contain ECG signals and uncorrelated noise, this first principal component represents the linear combination of the channels that shows the largest SNR. This increases the reliability and accuracy of the QRS detection.

The QRS detection takes place on the signal that is generated by the multi-channel QRS enhancement method. The QRS complexes are accurately detected by finding the maxima of the cross-correlation of the signal with a QRS template (Abboud and Beker 1989). Figure 4 shows an example of the QRS detection for the MECG and the FECG in an abdominal recording.

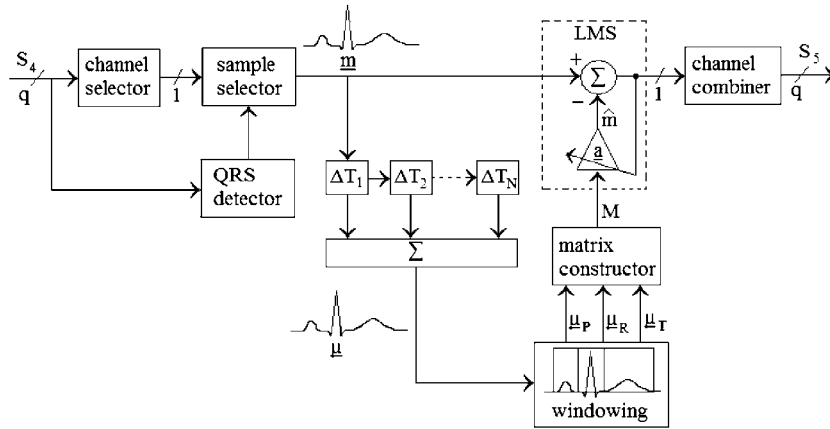
**2.2.4. MECG canceller.** The MECG is a quasi-periodic signal similar to the FECG. The periodicity of the MECG is usually slower than that of the FECG. In abdominal recordings, the MECG amplitude is an order of magnitude larger than the FECG amplitude (Peters *et al* 2001). Breathing effects and movements result in a varying distance and angle of the electrode with respect to the mother heart, leading to a time-varying morphology of the MECG. This time-variation is not proportional for the P, QRS and T wave because of their different dipole directions (Nelson and Geselowitz 1976).



**Figure 4.** QRS detection for the MECG (left plot) and FECG (right plot). The left plot shows  $S_4$  (upper five signals) and the signal generated by the multi-channel QRS enhancement method (bottom signal). The right plot shows  $S_5$  (upper five channels) and the signal generated by the QRS enhancement method (bottom signal). The detected QRS complexes are indicated by triangles.

The MECG cancellation takes place on each channel in  $S_4$  separately. It is based on the method proposed by (Cerutti *et al* 1986). The method consists of finding an estimate  $\hat{m}$  for each MECG complex  $m$  by an averaging and scaling procedure. The P wave, QRS complex and T wave durations are normally about 0.20 s, 0.10 s and 0.40 s, respectively (Guyton and Hall 1996). Therefore, the MECG complexes are defined as the samples within 0.25 s before and 0.45 s after the detected mother QRS complexes. An average MECG complex  $\mu$  is generated by averaging  $N$  preceding MECG complexes synchronized on their QRS complexes. The average MECG complex  $\mu$  is scaled with a constant  $a$  and the resulting MECG complex estimate  $\hat{m} = \mu a$  is subtracted from the actual MECG complex  $m$ . The scaling of  $\mu$  reduces the mismatch between the average and the actual MECG complex, which is caused by the time-varying morphology of the MECG. This scaling is based on the search for the least-mean square (LMS) error  $e^2$  between  $m$  and  $\mu$ , i.e.,  $e^2 = \min \|\mu a - m\|^2$ . Under the assumption that the MECG and FECG are not synchronized, for large  $N$  no FECG is present in  $\mu$ . As a result, the FECG remains unaffected during the cancellation of the MECG.

We propose an improvement of the scaling procedure that does not scale the average MECG complex as a whole, but performs a separate scaling of the P wave, the QRS complex and the T wave. In this way, the time-varying morphology of the MECG is more adequately taken into account. Figure 5 shows the proposed MECG canceller block scheme. Each average MECG complex  $\mu$  is windowed and the P wave, QRS complex and T wave isolated. All the samples within 0.05 s before and after the detected R peak are assigned to the QRS complex and stored in a vector  $\mu_R$ . In addition, the P-wave  $\mu_P$  and the T-wave vector  $\mu_T$  are built with the samples within 0.20 s before and 0.40 s after the QRS window, respectively. For maternal heart rates lower than 86 bpm, these timing assumptions provide non-overlapping MECG windows with a total length of 0.70 s. In the case of higher heart rates, however, the MECG cancellation is not disturbed if the heart rate is stable during the  $N$  averaged MECG complexes.



**Figure 5.** Block scheme of the MECG canceller. The delays  $\Delta T_1$ ,  $\Delta T_2$  and  $\Delta T_N$  correspond to the intervals between the actual and preceding MECG complexes.

The P wave, T wave and QRS complex vectors are assembled in a matrix  $M$  as follows:

$$M = \begin{pmatrix} | & 0 & 0 \\ \underline{\mu}_P & 0 & 0 \\ | & 0 & 0 \\ 0 & | & 0 \\ 0 & \underline{\mu}_{QRS} & 0 \\ 0 & | & 0 \\ 0 & 0 & | \\ 0 & 0 & \underline{\mu}_T \\ 0 & 0 & | \end{pmatrix}. \quad (2)$$

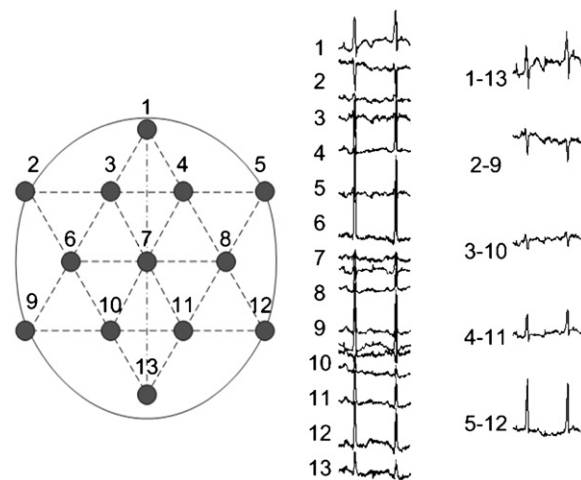
A scaling vector  $\underline{a} = (a_P \ a_{QRS} \ a_T)$  is defined. The MECG complex estimate  $\hat{\underline{m}}$  is given by  $\hat{\underline{m}} = M\underline{a}$ . The value of  $\underline{a}$  that leads to the least-squares error  $\min \|M\underline{a} - \underline{m}\|^2$  is

$$\underline{a} = (M^T M)^{-1} M^T \underline{m}. \quad (3)$$

$S_5$  may contain some erroneous FECG components induced by the presence of FECG remainings in  $\underline{\mu}$ . For  $N < \infty$ , the amplitude of the FECG components in the MECG complex estimate is about  $1/N$  times the FECG amplitude in  $S_4$  (neglecting the effect of the MECG canceller scaling). This implies that the erroneous FECG in  $S_5$  is about  $1/N$  times the FECG amplitude. We choose  $N = 10$ , resulting in an erroneous FECG amplitude of about  $1/10$  times the FECG amplitude in  $S_5$ .

A separate scaling of the Q, R and S wave could even further improve the performance of the MECG canceller as also the morphology of the QRS complex displays time-variation. However, our simulations indicate that this procedure significantly decreases the accuracy of the MECG estimation as a result of the similarity in shape and duration of the fetal QRS complex and the separate mother Q, R and S wave. Therefore, the separate scaling of the QRS complex has not been used in our final implementation.

**2.2.5. FECG detector.** After the removal of the baseline wander, the power-line interference and the MECG, the channels in  $S_5$  merely contain the FECG combined with EMG interference and measurement noise. The QRS detector detects the fetal QRS complexes enabling the



**Figure 6.** Illustration of the electrode placement on the mother's abdomen (left), and example of a 13-channel unipolar (middle) and a 5-channel bipolar (right) recording.

construction of a FHR trace. Moreover, this information is employed in the FECG detector. This detector averages  $N_{av}$  FECG complexes synchronized on the fetal QRS complex. We apply  $N_{av} = 150$  and, consequently, the SNR of the FECG is increased by a factor  $\sqrt{N_{av}} = 12$ . The result is a FECG complex estimate in each channel from which the relevant FECG parameters can be extracted for the assessment of the fetal condition.

### 2.3. Data set

Our data set contains 20 measurements recorded on 20 pregnant women at the Máxima Medical Center in Veldhoven (The Netherlands). Each recording consists of about 30 minutes of data. The recordings were made during various gestational ages, ranging from 19 weeks to early labour. Two of the five measurements during non-active labour were recorded after treatment with epidural analgesia. In 19 of the examined cases the baby had a vertex presentation, while in one case it had a breech presentation. The abdominal signal was recorded with a portable amplifier Porti5-24/ASD (TMS international), a 24-channel system for physiological research with battery supply, a gain of 20 and high input impedance ( $10^{12} \Omega$ ) in order to reduce the signal loss due to the electrode impedance.

The adopted lead configuration consisted of 13 unipolar contact electrodes on the abdomen of the mother as shown in figure 6. The common reference of the 13 unipolar recording was the average of all the connected unipolar inputs. These unipolar recordings represent the input mixture signal of the JADE algorithm.

For the sequential analysis method we adopted, the bipolar configuration calculated by subtracting the vertical aligned channels (1–13, 2–9, 3–10, 4–11 and 5–12). The resulting bipolar recordings represent the rows of the matrix  $S_1$ . This bipolar setup reduces the common mode signals resulting in the attenuation of the MECG contribution to the recordings. In many cases, depending on the position of the foetus in the belly, this procedure also enhances the relative contribution of the FECG. As a result, the SNR increases, resulting in an improved performance of the sequential analysis method.

## 2.4. Performance measures

**2.4.1. Fetal heart rate detection.** For a comparison of the performances of the proposed sequential analysis method and ICA, both methods are applied to the data set described in section 2.3. For each multi-channel recording a signal segment of 60 s is randomly selected. For the sequential analysis method, the selected 60 s of data are processed accordingly to the block scheme in figure 2. The result is a FHR trace and an average FECG per channel. For the ICA we define two preprocessing steps consisting of the removal of the baseline wander and the power-line interference as proposed in subsections 2.2.1 and 2.2.2. After these steps, the standard JADE algorithm, available in MATLAB, is applied resulting in 13 independent components. The QRS detection algorithm (presented in section 2.2.3) is applied to all the generated independent components. The feasible FHR trace(s) are then visually selected.

The performances of both methods are assessed by evaluating the FHR detection success rate and the reliability of the FHR detection. The FHR detection success rate is the percentage of patients for which a physiologically feasible FHR trace can be found. This is an important performance measure for FECG extraction methods because the detection of the FHR is a prerequisite for extracting FECG parameters that serve as an indicator of fetal health. In addition, the FHR allows us to enhance the quality of an extracted FECG, for example by averaging a number of FECG complexes. The FHR detection reliability is defined as 1 minus the ratio between the number of outliers in the FHR trace and the total number of points in the FHR trace. A point of the FHR trace is designated as an outlier if it deviates more than 10 bpm from the median FHR calculated over blocks of 10 s of FHR data.

**2.4.2. Quality of abdominal FECG.** The quality of the abdominal FECG recordings most probably influences the performance of FECG detection methods. We calculate two measures to express the quality of the recordings, i.e., the signal-to-noise ratio (SNR) and the signal-to-interference ratio (SIR). The SNR is the ratio between the FECG and the noise in the recordings, and the SIR is the ratio between the FECG and interference signal powers. For both methods the baseline wander and the power-line interference are removed. Therefore, their contribution to the interference signal power is omitted. Consequently, the SIR is defined as the ratio between the FECG and MECG signal power.

The actual FECG, the MECG and the noise are not known in real recordings. Consequently, for the calculation of the SIR and SNR, we have to resort to the estimates generated by the FECG detection. We use  $S_6$ , i.e., the averaged FECG in the channels obtained by the sequential analysis method, to derive an estimate of the signal power  $P_F$  of the FECG. Furthermore, the signal power of the MECG  $P_M$  is extracted from the difference between  $S_5$  and  $S_4$ . An estimate for the noise power  $P_N$  can be obtained by subtracting  $S_6$  from  $S_5$ . This leads to the following equations for the SNR and the SIR per channel  $j$ :

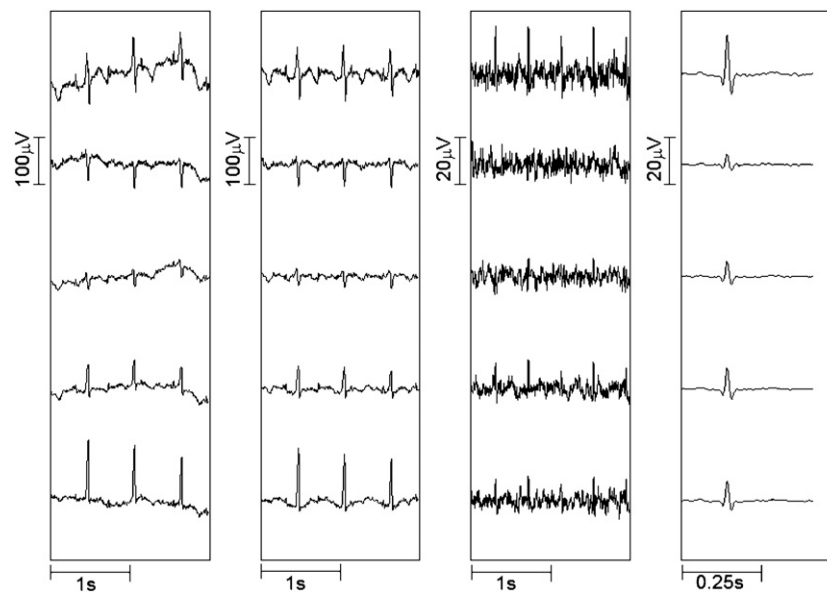
$$\text{SNR}_j = \frac{P_{F_j}}{P_{M_j}} = \frac{P_{S_{6,j}}}{P_{S_{5,j}-S_{6,j}}}, \quad (4)$$

$$\text{SIR}_j = \frac{P_{F_j}}{P_{N_j}} = \frac{P_{S_{6,j}}}{P_{S_{4,j}-S_{5,j}}}. \quad (5)$$

## 3. Results

### 3.1. Heart rate detection success

Table 1 shows the results of the FHR detection for the sequential analysis method and for JADE. The table gives the success rate for our data set with 20 abdominal FECG recordings. It also



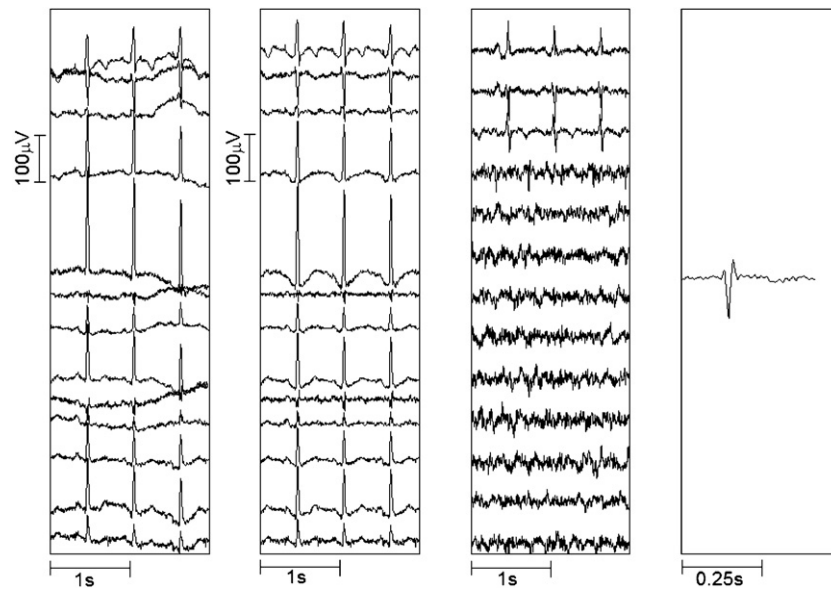
**Figure 7.** Sequential analysis method applied to a recording at 26 weeks of gestation. From left to right: bipolar abdominal signals  $S_1$  (2 s), signals after the removal of the baseline wander and the power-line interference  $S_3$  (2 s), channels after the removal of the MEGC  $S_5$  (2 s) and average FECG complex per channel  $S_6$ .

**Table 1.** FHR detection success rate and reliability for the sequential analysis method (SA) and JADE.

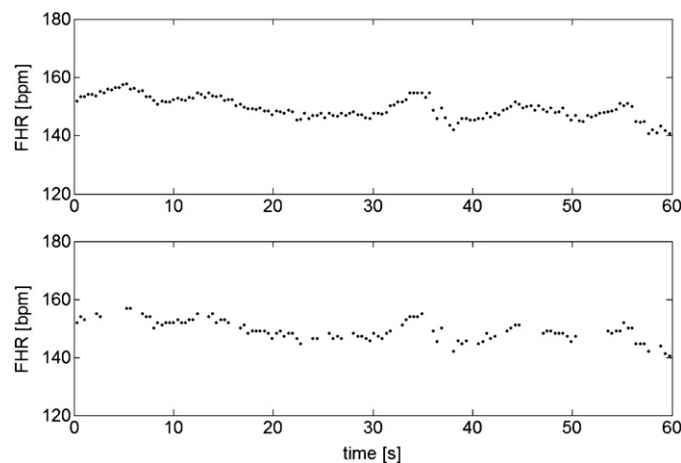
Weeks of gestation	Number of cases	Success rate (reliability)	
		SA	JADE
18–22	1	100% (86%)	0% (–)
23–27	1	100% (98%)	100% (100%)
28–32	5	60% (91%)	40% (93%)
33–37	5	80% (93%)	60% (86%)
38++	8	100% (95%)	75% (99%)
Overall	20	85% (93%)	60% (95%)

provides the average FHR detection reliability of the recordings for which a physiologically feasible FHR trace was found. In addition, it shows the results for different gestational ages, i.e., 18–22 weeks, 23–27 weeks, 28–32 weeks, 33–37 weeks and from 38 weeks to labour. Figures 7–9 display the results of the sequential analysis and JADE on an abdominal FECG recording.

The sequential analysis method was more successful in finding the FHR than JADE for all gestational ages. The overall success rate of the sequential analysis method was significantly higher (85% versus 60%). The sequential analysis method succeeded for all the cases where JADE succeeded. The overall FHR reliability of the sequential analysis and JADE was comparable (93% versus 95%). When taking into account only those cases where both methods were successful, the reliability of the sequential analysis and JADE was 96% and 95%, respectively.

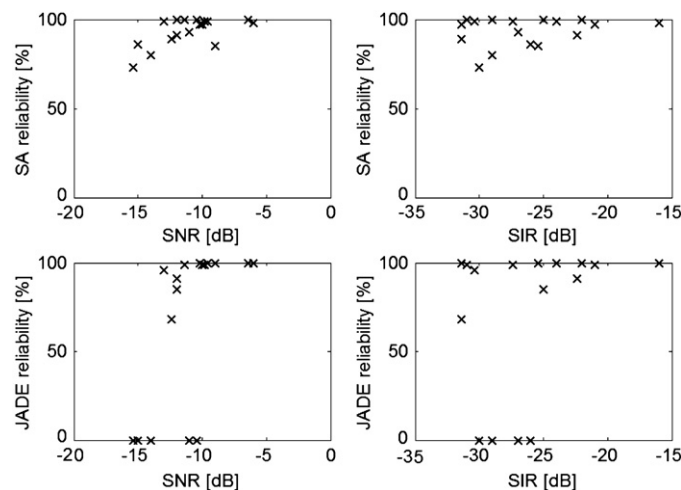


**Figure 8.** JADE algorithm applied to the recording of figure 7. From left to right: unipolar abdominal signals  $\underline{x}$  (2 s), channels after the removal of the baseline wander and the power-line interference (2 s), estimated source signals  $\underline{s}$  (2 s) and average FECG complex obtained from source signal 4.



**Figure 9.** FHR traces of the recording shown in figures 7 and 8. The top figure is obtained by the sequential analysis method (FHR reliability 100%), the bottom figure by JADE (FHR reliability 85%).

The recordings at 28–32 weeks of gestation clearly show a decreased success rate for both methods. Difficulties in obtaining the fetal heart rate in this period have been reported by several authors (Bolte 1961, Bergveld *et al* 1986, Oldenburg and Macklin 1977, Oostendorp *et al* 1989, Taylor *et al* 2003). They have been attributed to a decreased FECG amplitude caused by the presence of the vernix caseosa, a fatty and isolating layer which appears around 28 weeks and starts deteriorating around 32 weeks of gestation.



**Figure 10.** FHR detection reliability of the sequential analysis method (SA) and JADE as a function of the SNR and the SIR. For the unsuccessful cases of JADE the FHR detection reliability is equal to zero.

If we make a distinction between recordings made antepartum (15 cases) and intrapartum (5 cases), the FHR detection success rates for our method versus JADE were 80% versus 53%, and 100% versus 80%, respectively.

### 3.2. Quality of abdominal FECG

For all the patients, the SNR and SIR were calculated per channel according to equations (4) and (5). In figure 10 the mean SNR and SIR of the channels have been plotted against the FHR detection reliability for each patient.

A larger mean SNR and SIR correspond to a larger FHR detection reliability for both the sequential analysis method and JADE. JADE seems not to guarantee a successful FHR detection when the mean SNR and SIR of the channels is smaller than  $-10$  and  $-25$  dB, respectively. The sequential analysis method still performs adequately at smaller SNR and SIR. This indicates that the sequential analysis method is less sensitive to noise and, therefore, more robust than JADE for the detection of the FHR in abdominal FECG recordings.

## 4. Discussion

The measurement of a reliable FECG from abdominal surface recordings would represent an important achievement in gynaecology as it allows monitoring the condition of the foetus at several stages of pregnancy by relatively inexpensive equipment, which, if successful, could even be adopted for at-home monitoring.

Nowadays several researchers apply ICA for the detection of the FECG from abdominal recordings. However, the suitability of this technique for this application is not obvious given the fact that the purely mathematical basis of the method does not consider the characteristics of the signals involved. It has been reported that a good performance of ICA for FECG detection requires (Ifeachor *et al* 2004)

- (i) that the FECG is visible above the noise floor,
- (ii) that the number of available channels is larger than the number of desired independent signals due to the variable number of interference sources.

In this paper, we confirm the validity of (i) as the performance of JADE results highly dependent on the SNR of the FECG. If the mean SNR of the channels was smaller than  $-10$  dB, FHR detection success could not be guaranteed. The success rate of 60% over the complete data set achieved for ICA is much smaller than the 85% reported in the literature by Taylor (Taylor *et al* 2003), who applied ICA to a large number of abdominal recordings with different gestational ages. The reason for the smaller ICA success rate in our data set is very likely related to the smaller SNR of our recordings as the recordings used by Taylor fulfilled some strict conditions concerning noise levels. The measurement protocol described in Taylor *et al* (2003) comprised skin preparation with an abrasive tape and electrode impedance control. Also, the measurement only started when visual assessment confirmed that the EMG level was satisfactory. In the clinic, a fast recording procedure in which a strict measurement protocol regarding the noise levels can be omitted is very desirable. Therefore, our inclusion criteria for the data acquisition did not comprise limits to the EMG level. Moreover, we did not prepare the skin by rubbing it or assess electrode impedances before recording. These factors cause that in our recordings the measurement noise and EMG levels were most likely larger and, therefore, that the SNR was significantly smaller than in the recordings that were used by Taylor.

The presence of a large amount of EMG interference in the recordings also has an impact on (ii). The mixtures in our application consist of a large number of source components that can completely overwhelm the desired FECG source, like two or three MECG source components and a number of abdominal EMG sources. In fact, the EMG interference on each channel consists of the sum of several active muscle sources, whose contribution depends on the distance between the muscle source and the electrode. As the EMG does not have a Gaussian distribution (Kaplanis *et al* 2000), all the muscle sources that contribute to the EMG interference in the channels are separate source signals. This may result in a conflict with (ii) and, therefore, lead to unsuccessful FECG extraction. In ambulant recordings or during active labour the fulfilment of (ii) seems even more questionable given the large levels of abdominal and uterine muscle activity and the mothers need for mobility, which result in large movement artefacts in the recordings.

The sequential analysis method that we propose is non-blind. It is tailored to the *a priori* knowledge about the characteristics of the interference signals and the signal of interest. For example, the periodicity of the MECG and the difference in periodicity of the MECG and the FECG are exploited in the estimation of the MECG by means of averaging and the time-variance of the morphology of the MECG is accounted for by scaling the MECG components separately. Moreover, the small correlation of the EMG signals and the noise among the channels (after subtraction of the MECG) ensures that the channel with the largest variance of the combined channels, i.e., the first principal component, contains merely FECG.

The adopted definition of the MECG complexes  $\underline{m}$  in the MECG canceller results in non-overlapping windows with a total length of 0.70 s for maternal heart rates up to 86 bpm. For higher heart rates, the MECG windows overlap and subsequent P waves and preceding T waves may be included in the windows. Nevertheless, such a window overlapping may not disturb the MECG cancellation as long as the heart rate is stable during the  $N$  complexes used for averaging, though the independency of the P and T wave scaling is partially lost. Therefore, future development may comprise the use of dynamic MECG windows which can also take into account the variation of the QT segment due to different heart rates (Clifford *et al* 2006).

## 5. Conclusion

A new method for FECG detection in multi-channel abdominal electrical recordings is proposed. The method is based on a sequential analysis of the interference signals such as the baseline wander, the power-line interference and the MECG. The outputs of the sequential estimation method are the FHR and the FECG in each channel. We compared the results of our method with those of the JADE blind source separation technique on a database containing 20 real abdominal recordings from women with different gestational ages. The performance of the two techniques was assessed by evaluating the FHR detection success rate. The results show that our method outperforms the JADE algorithm. Our findings indicate that for an accurate FECG detection, JADE requires a larger SNR of the abdominal FECG than our method. Therefore, the sequential estimation method can be considered more robust for FECG detection than the BSS technique.

Our future research will focus on the definition of an optimal electrode configuration including the possibility of using a reduced number of electrodes. The employment of a restricted number of electrodes is feasible with the proposed sequential analysis method while ICA requires the number of channels to be equal or larger than the number of sources. Ideally, the use of a single abdominal channel would be possible if an optimal electrode position for FECG SNR could be detected. This would imply a significant improvement of the patient comfort and a faster recording procedure, favouring the application of our method to ambulant and active labour recordings.

## References

- Abbound S and Beker A 1989 An improved detection algorithm in fetal electrocardiography *J. Electrocardiol.* **22** (Suppl.) 238–42
- Abbound S and Sadeh D 1989 Spectral analysis of the fetal electrocardiogram *Comput. Biol. Med.* **19** 409–15
- Abbound S and Sadeh D 1990 Power spectrum analysis of fetal heart rate variability using the abdominal maternal electrocardiogram *J. Biomed. Eng.* **12** 161–4
- Bemmel J H V and van der Weide H 1966 Detection procedure to represent the foetal heart rate and electrocardiogram *IEEE Trans. Biomed. Eng.* **13** 175–82
- Bergveld P, Kolling A J and Peuscher J 1986 Real-time fetal ECG recording *IEEE Trans. Biomed. Eng.* **33** 505–9
- Bolte A 1961 Zur Ableitung und Bewertung foetaler Hertzaktionspotentiale bei schwangeren Frauen *Arch. Gynäkol.* **194** 594–611
- Callaerts D, Vanderschoot J, Vandewalle J, Sansen W, Vantrappen G and Janssens J 1986 An adaptive on-line method for the extraction of the complete fetal electrocardiogram from cutaneous multilead recordings *J. Perinat. Med.* **14** 421–33
- Cardoso J F 1989 Source separation using higher order moments *Proc. ICASSP* pp 2109–12
- Cerutti S, Baselli G, Civardi S, Ferrazzi E, Marconi A M, Pagani M and Pardi G 1986 Variability analysis of fetal heart rate signals as obtained from abdominal electrocardiographic recordings *J. Perinat. Med.* **14** 445–52
- Clifford G D, Azuaje F and McSharry P E (ed) 2006 *Advanced Methods and Tools for ECG Data Analysis* (Boston: Artech House)
- Comani S, Mantini D, Lagatta A, Esposito F, Luzio S D and Romani G 2004 Time course reconstruction of fetal cardiac signals from fMCG: independent component analysis versus adaptive maternal beat subtraction *Physiol. Meas.* **25** 1305–21
- Comon P 1994 Independent component analysis: a new concept? *Signal Process.* **36** 287–314
- Crowe J A, Harrison A and Hayes-Gill B R 1995 The feasibility of long-term fetal heart rate monitoring in the home environment using maternal abdominal electrodes *Physiol. Meas.* **16** 195–202
- Crowe J A *et al* 1996 Antenatal assessment using the FECG obtained via abdominal electrodes *J. Perinat. Med.* **24** 43–53
- Friesen G M, Jannett T C, Jadallah M A, Yates S L, Quint S R and Nagle H T 1990 A comparison of the noise sensitivity of nine QRS detection algorithms *IEEE Trans. Biomed. Eng.* **37** 85–98
- Gradwohl J R, Pottala E W, Horton M R and Bailey J J 1988 Comparison of two methods for removing baseline wander in the ECG *Proc. Comput. Cardiol.* pp 493–6

- Guyton A C and Hall J E 1996 *Textbook of Medical Physiology* 9th edn (Philadelphia, PA: Saunders)
- Harmeling S, Meinecke F and Müller K R 2004 Injecting noise for analysing the stability of ICA components *Signal Process.* **84** 255–6
- Hyvarinen A 1999 Fast and robust fixed point algorithm for independent component analysis *IEEE Trans. Neural Netw.* **10** 626–34
- Hyvarinen A, Karhunen J and Oja E 2001 *Independent Component Analysis* (New York: Wiley)
- Ifeachor E C, Outram N J, Henderson G T, Wimalaratna H S K, Hudson N, Sneyd R, Dong C and Bigan C 2004 Nonlinear methods for biopattern analysis: role and challenges *Proc. Ann. Int. Conf. IEEE EMBS* pp 5400–6
- Jutten C and Taleb A 2000 Source separation: from dusk till dawn *Proc. ICA2000* pp 15–26
- Kaplanis P A, Pattichis C S, Hadjileontiadis L J and Panas S M 2000 Bispectral analysis of surface EMG *IEEE MELECON 2* 770–3
- Laguna P, Jane R and Caminal P 1992 Adaptive filtering Of ECG baseline wander *Proc. Ann. Int. Conf. IEEE EMBS* **2** 508–9
- Lathauwer L D, Moor B D and Vanderwalle J 2000 Fetal electrocardiogram extraction by blind source subspace separation *IEEE Trans. Biomed. Eng.* **47** 567–72
- Lewis M J 2003 Review of electromagnetic source investigations of the fetal heart *Med. Eng. Phys.* **25** 801–10
- Martens S M M, Mischi M, Oei S G and Bergmans J W M 2006 An improved adaptive power line interference canceller for electrocardiography *IEEE Trans. Biomed. Eng.* **53** 2220–31
- Martens S M M, Sluijter R J, Oei S G and Bergmans J W M 2005 Improving QRS detection in multi-channel electrocardiography by principal component analysis *IFMBE Proc. EMBEC (CD)* **11**
- McManus C D, Teppner U, Neubert D and Lobodzinski S M 1985 Estimation and removal of baseline drift in the electrocardiogram *Comput. Biomed. Res.* **18** 1–9
- Meijer P B W J 1981 A new technique for the suppression of the MECG *IEEE Trans. Biomed. Eng.* **28** 248–353
- Meyer C R and Keiser H N 1977 Electrocardiogram baseline noise estimation and removal using cubic splines and state-space computation techniques *Comput. Biomed. Res.* **10** 459–70
- Nelson C and Geselowitz D 1976 *The Theoretical Basis of Electrocardiology* (Oxford: Oxford University Press)
- Oldenburg J T and Macklin M 1977 Processing the abdominal fetal ECG *IEEE Trans. Biomed. Eng.* **24** 501–7
- Onaral B, Sun H H and Schwan H P 1984 Electrical properties of bioelectrodes *IEEE Trans. Biomed. Eng.* **31** 827–32
- Oostendorp T 1989 Modelling the foetal ECG *PhD Thesis* University of Nijmegen, The Netherlands
- Oostendorp T F, van Oosterom A and Jongsma H W 1989 The effect of changes in the conductive medium on the fetal ECG throughout gestation *Clin. Phys. Physiol. Meas.* **10** (Suppl. B) 11–20
- Peters M, Crowe J, Pieri J F, Quarero H, Hayes-Gill B, James D, Stinstra J and Shakespeare S 2001 Monitoring the fetal heart non-invasively: a review of methods *J. Perinat. Med.* **29** 408–16
- Plonsey R and Fleming D G 1969 *Bioelectric Phenomena* (New York: McGraw-Hill)
- Raifel M and Ron S 1997 Estimation of slowly changing components of physiological signals *IEEE Trans. Biomed. Eng.* **44** 215–20
- Sabry-Rizk M, Zgallai W, McLean A, Carson E R and Grattan K T V 2001 Virtues and vices of source separation using linear independent component analysis for blind source separation of non-linearly coupled and synchronised fetal and mother ECGs *Proc. Ann. Conf. IEEE EMBS* vol 2, pp 1985–9
- Sornmo L 1993 Time-varying digital filtering of ECG baseline wander *Med. Biol. Eng. Comput.* **31** 503–8
- Symonds E M, Sahota D and Chang A 2001 *Fetal Electrocardiography* (London, UK: Imperial College Press)
- Taylor M J, Smith M J, Thomas M, Green A R, Cheng F, Oseku-Afful S, Wee L Y, Fisk N M and Gardiner H M 2003 Non-invasive fetal electrocardiography in singleton and multiple pregnancies *Br. J. Obstet. Gynaecol.* **110** 668–78
- Taylor M J, Thomas M J, Smith M J, Oseku-Afful S, Fisk N M, Green A R, Paterson-Brown S and Gardiner H M 2005 Non-invasive intrapartum fetal ECG: preliminary report *Br. J. Obstet. Gynaecol.* **112** 1016–21
- van Alste J A, van Eck W and Herrmann O E 1986 ECG baseline wander reduction using linear phase filters *Comput. Biomed. Res.* **19** 417–27
- van Geijn H P and Copray F J A 1994 *A Critical Appraisal of Fetal Surveillance* (Amsterdam: Excerpta Medica)
- Widrow B, Glover J R, McCool J, Kaunitz J, Williams C S, Hearn R H, Zeidler J R, Dong E and Goodlin R 1975 Adaptive noise cancelling: principles and applications *Proc. IEEE* **62** 1692–716
- Zarzoso V and Nandi A K 2001 Noninvasive fetal electrocardiogram extraction: blind separation versus adaptive noise cancellation *IEEE Trans. Biomed. Eng.* **48** 12–8
- Zarzoso V, Nandi A K and Bacharakis E 1997 Maternal and foetal ECG separation using blind source separation methods *IMA J. Math. Appl. Med. Biol.* **14** 207–25